



THE OPMS 1011 STAINLESS STEEL CUTTING HALVA MACHINE WITH FIXED KNIFE

PACKAGING DETAILS

- The capacity standart is 750 kg/hour, it changes as to weight in grams of product.
- Possibility cutting 80 gr, 200 gr, 250 gr, 400 gr, 500 gr, 1000 gr

CONSTRUCTION

- Heavey duty full steel frame
- Product handling line is stainless steel finishing , rest of the machine chassis is electrostatic dyed
- Body design for easy clean down.
- Heavey duty roller for easy relocation.
- Heavey duty adjustable feet for permanent positioning.

FEATURE DETAILS

- 2 pieces reducers(There are swiches and safety swiches)
- It works forward-back with especial design ballscrew system that is beared skid lateral
- Bit pan of halva
- A piece of pattern is given
- The patterns is one system (36x36x60)is used in whole measures.
- Angular cutting knife system(imported press knife)
- The tolerance of change weight in grams is minimum.
- Cutting is L cutting.it cuts width and lenght
- Measures of pan and making weight in grams(mm)is given by technical information.
- Our cages is chrome and measures' are 40x40.Special laser technic is used for not knife deflecting.
- The battens that boosts halva is chrome,two sides are apparent and can be cleaned.(Laser Technic is used)
- Fast,safe and sturdy
- Low cost

SPECIFICATIONS

Pattern	360x360x60 mm	Consult ORME for other dimensions	General Machine Dimensions	Width : 1300 mm
Weight in grams	80 gr. , 200 gr. , 250 gr.			Height : 950 mm
Dimensions	400 gr. , 500 gr. , 1000 gr.		Length : 1450 mm	
Machine Speed	750 kg./h		App. Machine Weight : 600 kg.	
Longitudinally Cutting	72 mm , 120 mm , 180 mm		Pneumatic Consumption	NO
Transverse Cutting	60 mm , 72 mm , 90 mm , 120 mm		Electrical Voltage	380 Volt / 3 Phase 50 Hz.
Knife Dimension	40X40 mm		Power Consumption	2 kW
			Motor Power	2 kW

The all technical specification in this catalogue are with a view to presentation. ORME reserves to right to change specifications without prior notice -1/2-

***THE OPMS 1011
STAINLESS STEEL CUTTING HALVA MACHINE
WITH FIXED KNIFE***

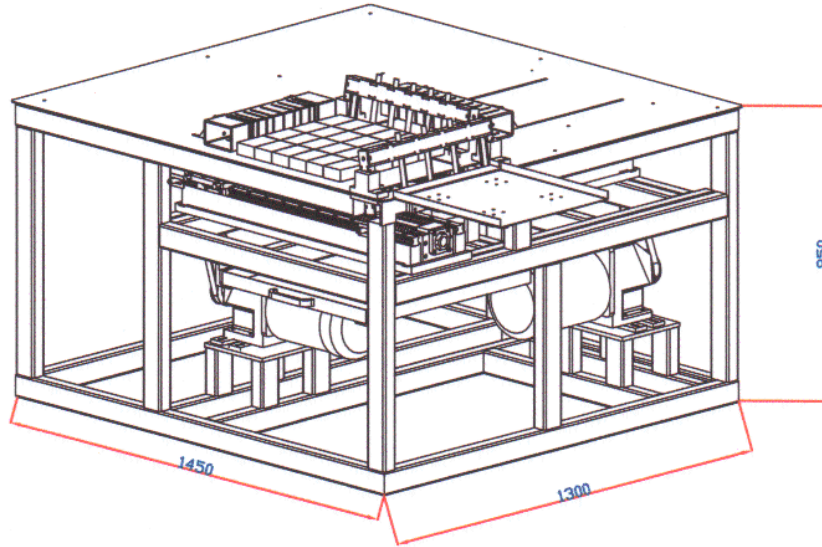

The all technical specification in this catalogue are with a view to presentation. ORME reserves to right to change specifications without prior notice -2/2-