



THE OPMS 1003 ***STAINLESS STEEL WITH SINGLE SERVO*** ***MOTION CONTROL PACKAGING MACHINE***

PACKAGING DETAILS

- Suitable heat-sealable films such as paper or aluminium laminations, OPP , BOPP cellophane with ready stick sides and cold sealable films of same quality.
- The range of goods that can be packed : chocolates, sweet confectioneries, biscuits, cakes, halva, sandwiches, finger foods, and other applications such as sponges, cleaning cloths, soaps, rubbish bags, and other solid products can also be packed. This machine's packing capacity is approximately 150-200 pac/min. The capacity is dependent on used wrapping material type and stick type (hot or cold) and also sizes of product been packaged. From 40-80 gr. to 1 kg. can be packaged on this model without any other additional parts added.

CONSTRUCTION

- Heavy duty full steel frame
- Product handling line and all chassis cover is stainless steel.
- Body design for easy clean down.
- Heavy duty roller for easy relocation.
- Heavy duty adjustable feet for permanent positioning.

FEATURE DETAILS

- The chin system is double chin which has a adjustable angle blades.
- Single bobbin head is fitted with a extra bearing with a total of 2 bearings to stop any flexing from loading.
- The Packet length dimension can be set to continuously variable any dimension with servo control between the minimum and maximum value. The conveyor and chin group communicate with a CMZ processor via analog.
- Automatic break system.
- More power of resistance and more robust and mechanically advanced.
- The automatic packaging settings can be done with on touch screen control panel.
- The sewing group roller press is adjustable.
- Conveyor is adjustable according to the product.
- The chin speed can be set to continuously variable any speed between the minimum and maximum value, while machine is operating.
- Adjustable folding unit.
- CMZ 158 twin axis control system.
- ESA W505 touch operation control panel 5,7.
- MOKON 2000 Rpm , 5 Nm servo motor + driver

SPECIFICATIONS

Chin Width	160 mm	Consult ORME for other dimensions	General Machine Dimensions	Width : 850 mm
Product Dimensions	Width : 20-150 mm			Height : 1800 mm
	Height: 5-60 mm		Length : 3300 mm	
	Length : 60-260 mm		App. Machine Weight : 700 kg.	
Machine Speed	150-200 pac/min.		Pneumatic Consumption	NO
Max. Spool Width	400 mm		Electrical Voltage	380 Volt / 3 Phase 50 Hz.
Max. Spool Diameter	450 mm		Power Consumption	4.1 kW – 20 Amp.
Spool Inside Diameter	60-76 mm		Motor Power / Heater Power	2.1 kW – 2 kW

The all technical specification in this catalogue are with a view to presentation. ORME reserves to right to change specifications without prior notice -1/2-

THE OPMS 1003
STAINLESS STEEL WITH SINGLE SERVO
MOTION CONTROL PACKAGING MACHINE

FRONT OF MACHINE

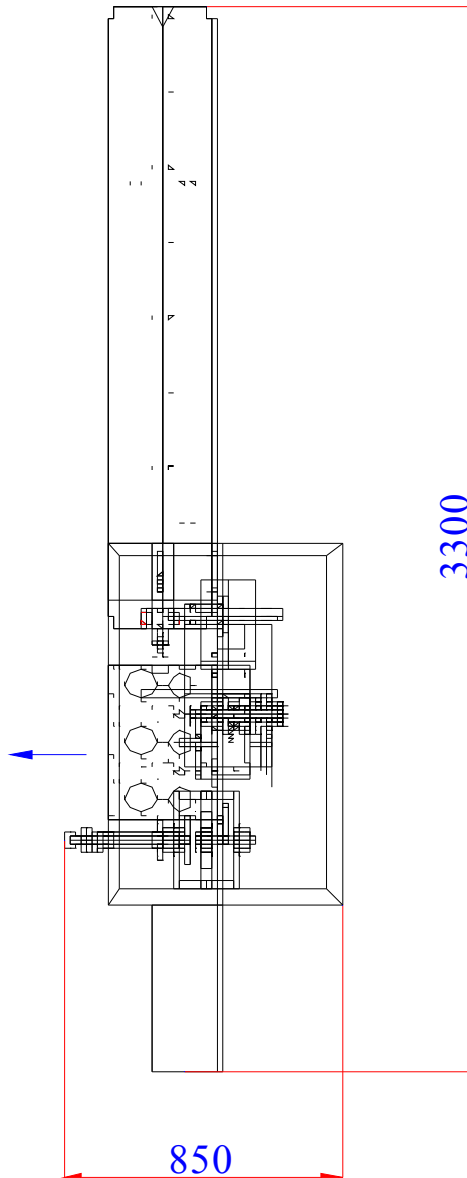

The all technical specification in this catalogue are with a view to presentation. ORME reserves to right to change specifications without prior notice -2/2-