



***THE OPMS 1003***  
***STAINLESS STEEL WITH SINGLE SERVO***  
***MOTION CONTROL PACKAGING MACHINE***  
***WITH SINGLE BAND SIDE FEEDING***

**PACKAGING DETAILS**

- Suitable heat-sealable films such as paper or aluminium laminations, OPP , BOPP cellophane with ready stick sides and cold sealable films of same quality.
- The range of goods that can be packed : chocolates, sweet confectioneries, biscuits, cakes, halva, sandwiches, finger foods, and other applications such as sponges, cleaning cloths, soaps, rubbish bags, and other solid products can also be packed. This machine's packing capacity is approximately 150-200 pac/min. The capacity is dependent on used wrapping material type and stick type (hot or cold) and also sizes of product been packaged. From 40-80 gr. to 1 kg. can be packaged on this model without any other additional parts added.

**CONSTRUCTION**

- Heavy duty full steel frame
- Product handling line and all chassis cover is stainless steel.
- Body design for easy clean down.
- Heavy duty roller for easy relocation.
- Heavy duty adjustable feet for permanent positioning.

**FEATURE DETAILS**

- Single band ; band length is 1 mt. with side tray.
- Band is with AC motor-gear box and speed controller
- The chin system is double chin which has a adjustable angle blades.
- Single bobbin head is fitted with a extra bearing with a total of 2 bearings to stop any flexing from loading.
- The Packet length dimension can be set to continously variable any dimension with servo control between the minimum and maximum value. The conveyor and chin group communicate with a CMZ processor via analog.
- Automatic break system.
- More power of resistance and more robust and mechanically advanced.
- The automatic packaging settings can be done with on touch screen control panel.
- The sewing group roller press is adjustable.
- Conveyor is adjustable according to the product.
- The chin speed can be set to continously variable any speed between the minimum and maximum value, while machine is operating.
- Adjustable folding unit.
- CMZ 158 twin axis control system.
- ESA W505 touch operation control panel 5,7.
- MOKON 2000 Rpm, 5 Nm servo motor + driver

**SPECIFICATIONS**

<b>Chin Width</b>	160 mm	Consult ORME for other dimensions	<b>General Machine Dimensions</b>	Width : Look at Page2/2
<b>Product Dimensions</b>	Width : 20-150mm			Height : 1800
	Height: 5-60 mm			Lenght : Look at Page2/2
	Lenght : 60-260mm			<b>App. Machine Weight : 900 kg.</b>
<b>Machine Speed</b>	150-200 pac/min.		<b>Pneumatic Consumption</b>	NO
<b>Max. Spool Width</b>	400 mm		<b>Electrical Voltage</b>	380 Volt / 3 Phase 50 Hz.
<b>Max. Spool Diameter</b>	450 mm		<b>Power Consumption</b>	4.85 kW – 22 Amp.
<b>Spool Inside Diameter</b>	60-76 mm		<b>Motor Power / Heater Power</b>	2.85 W – 2 kW

The all technical specification in this catalogue are with a view to presentation. ORME reserves to right to change specifications without prior notice -1/2-

***THE OPMS 1003***  
***STAINLESS STEEL WITH SINGLE SERVO***  
***MOTION CONTROL PACKAGING MACHINE***  
WITH SINGLE BAND SIDE FEEDING

Please select type box which you prefer (TYPE A or TYPE B)

TYPE A FEEDING FROM FRONT SIDE

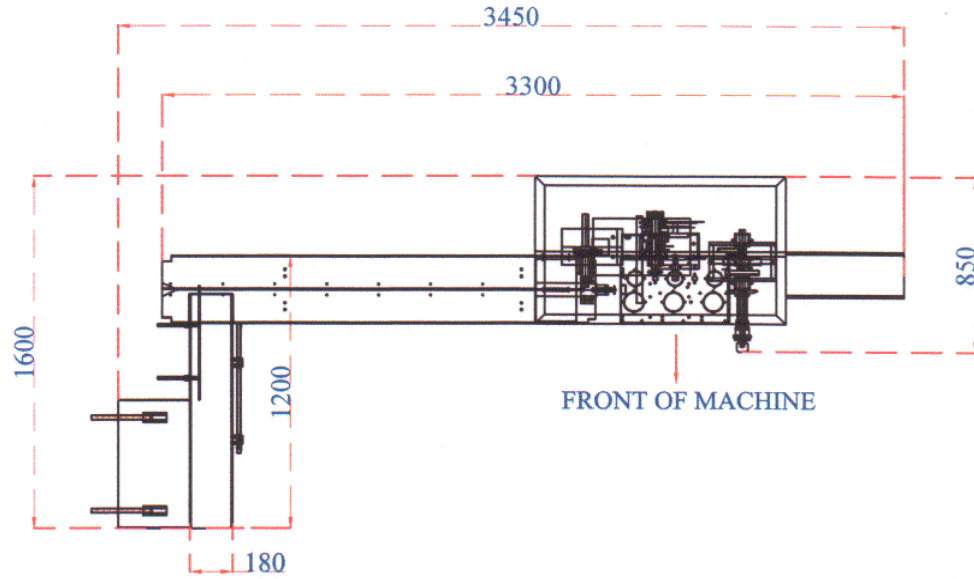

TYPE B FEEDING FROM BACK SIDE

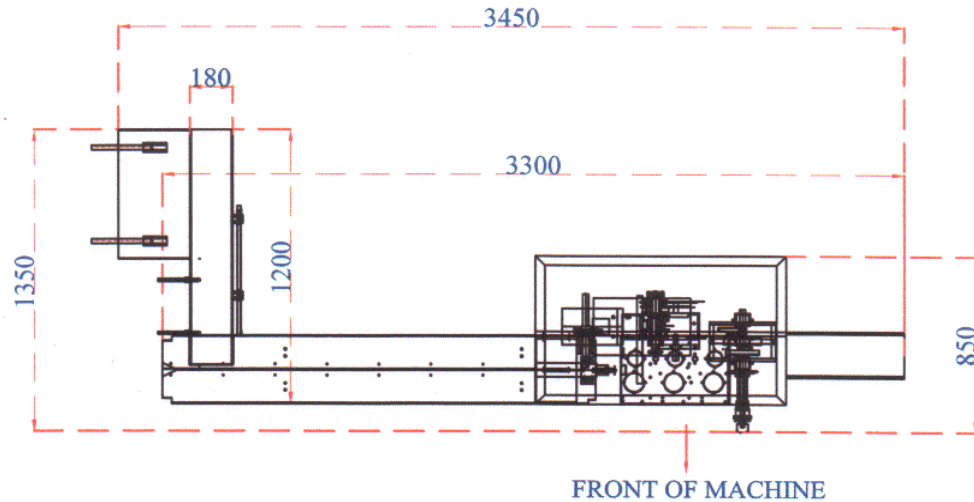

The all technical specification in this catalogue are with a view to presentation. ORME reserves to right to change specifications without prior notice -2/2-