



THE OPMS 1002 ELECTROSTATIC DYED BREAD PACKAGING MACHINE

PACKAGING DETAILS

- Suitable heat-sealable films such as paper or aluminium laminations, OPP , BOPP cellophane with ready stick sides and cold sealable films of same quality.
- Bread or pastry products can be packed one by one with this model. This machine's packing capacity is approximately 70-80 pac/min. The capacity is dependent on used wrapping material type and sizes of product been packaged. From 40-80 gr. to 1 kg. can be packaged on this model without any other additional parts added.

CONSTRUCTION

- Heavey duty full steel frame
- Product handling line is stainless steel finishing , rest of the machine chassis is electrostatic dyed
- Body design for easy clean down.
- Heavey duty roller for easy relocation.
- Heavey duty adjustable feet for permanent positioning.

FEATURE DETAILS

- The chin system is single chin which has a adjustable angle blades.
- Single bobbin head is fitted with a extra bearing with a total of 2 bearings to stop any flexing from loading.
- The Packet length dimension can be set to continously variable any dimension between the minimum and maximum value.
- Automatic break system.
- More power of resistance and more robust and mechanically advanced.
- The automatic packaging settings can be done with buttons on control panel.
- The chin speed can be set to continously variable any speed between the minimum and maximum value, while machine is operating.
- Adjustable folding unit.
- The electric panel is connected to the outside of the machine.

SPECIFICATIONS

Chin Width	200 mm	Consult ORME for other dimensions	General Machine Dimensions	Width : 850 mm
Product Dimensions	Width : 40-190 mm			Height : 1800 mm
	Height: 10-100 mm		Length : 3300 mm	
	Length : 100-600 mm		App. Machine Weight : 700 kg.	
Machine Speed	70-80 pac/min.		Pneumatic Consumption	NO
Max. Spool Width	520 mm		Electrical Voltage	380 Volt / 3 Phase 50 Hz.
Max. Spool Diameter	450 mm		Power Consumption	3.5 kW – 15 Amp.
Spool Inside Diameter	60-76 mm		Motor Power / Heater Power	1.5 kW – 2 kW

The all technical specification in this catalogue are with a view to presentation. ORME reserves to right to change specifications without prior notice -1/2-

***THE OPMS 1002
ELECTROSTATIC DYED BREAD PACKAGING
MACHINE***

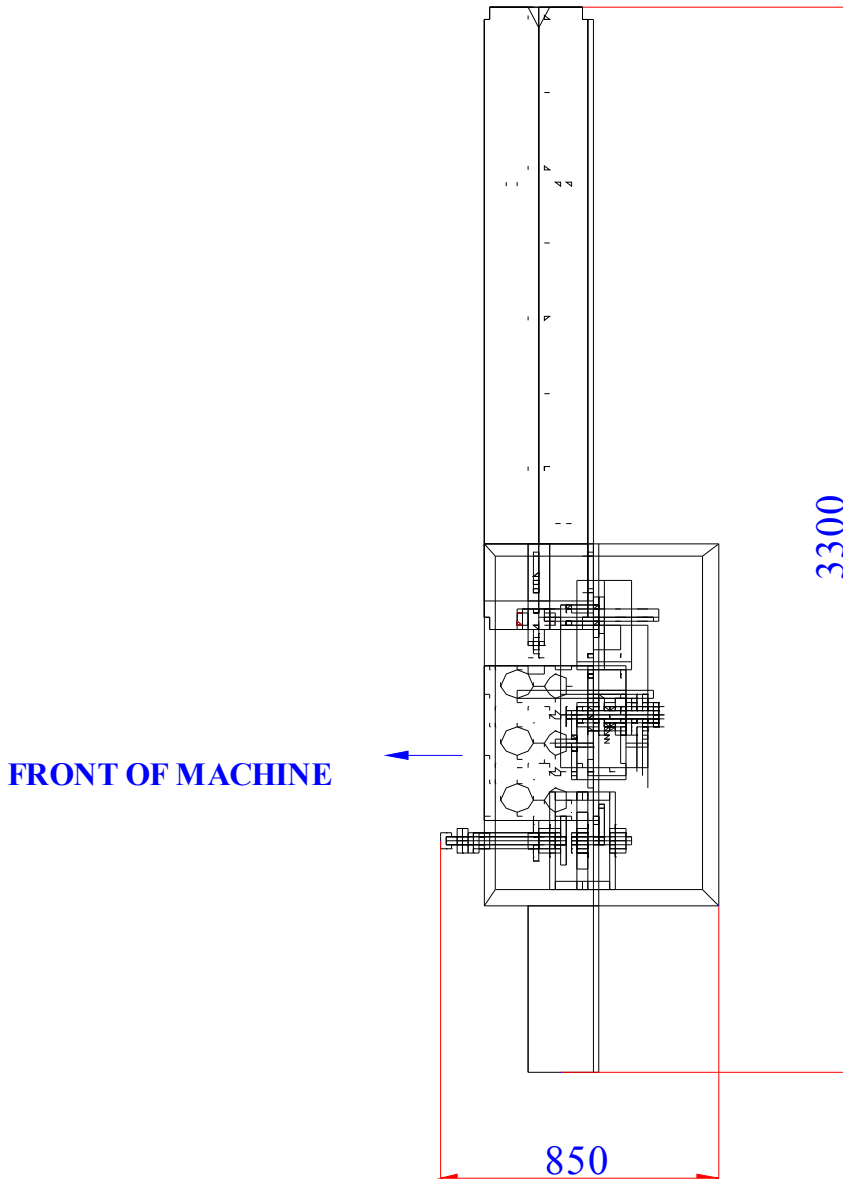

The all technical specification in this catalogue are with a view to presentation. ORME reserves to right to change specifications without prior notice -2/2-