



THE OPMS 1003 STAINLESS STEEL PACKAGING MACHINE WITH SINGLE BAND SIDE FEEDING

PACKAGING DETAILS

- Suitable heat-sealable films such as paper or aluminium laminations, OPP , BOPP cellophane with ready stick sides and cold sealable films of same quality.
- The range of goods that can be packed : chocolates, sweet confectioneries, biscuits, cakes, halva, sandwiches, finger foods, and other applications such as sponges, cleaning cloths, soaps, rubbish bags, and other solid products can also be packed. This machine's packing capacity is approximately 150-200 pac/min. The capacity is dependent on used wrapping material type and stick type (hot or cold) and also sizes of product been packaged. From 40-80 gr. to 1 kg. can be packaged on this model without any other additional parts added.

CONSTRUCTION

- Heavy duty full steel frame
- Product handling line and all chassis cover is stainless steel.
- Body design for easy clean down.
- Heavy duty roller for easy relocation.
- Heavy duty adjustable feet for permanent positioning.

FEATURE DETAILS

- Single band ; band length is 1 mt. with side tray.
- Band is with AC motor-gear box and speed controller
- The chin system is double chin which has a adjustable angle blades.
- Single bobbin head is fitted with a extra bearing with a total of 2 bearings to stop any flexing from loading.
- The Packet length dimension can be set to continuously variable any dimension between the minimum and maximum value.
- Automatic break system.
- More power of resistance and more robust and mechanically advanced.
- The automatic packaging settings can be done with buttons on control panel.
- Photocell system with magnetic clutch.
- The chin speed can be set to continuously variable any speed between the minimum and maximum value, while machine is operating.
- Adjustable folding unit.
- The electric panel is connected to the outside of the machine.

SPECIFICATIONS

Chin Width	160 mm	Consult ORME for other dimensions	General Machine Dimensions	Width : Look at Page 2/2
Product Dimensions	Width : 20-150mm			Height : 1800 mm
	Height: 5-60 mm		Length : Look at Page 2/2	
	Length : 60-260 mm		App. Machine Weight : 900 kg.	
Machine Speed	150-200 pac/min.		Pneumatic Consumption	NO
Max. Spool Width	400 mm		Electrical Voltage	380 Volt / 3 Phase 50 Hz.
Max. Spool Diameter	450 mm		Power Consumption	4.25kW – 20 Amp.
Spool Inside Diameter	60-76 mm		Motor Power / Heater Power	2.25 kW – 2 kW

The all technical specification in this catalogue are with a view to presentation. ORME reserves to right to change specifications without prior notice -1/2-

***THE OPMS 1003
STAINLESS STEEL PACKAGING MACHINE
WITH SINGLE BAND SIDE FEEDING***

Please select type box which you prefer (Type A or Type B)

TYPE A FEEDING FROM FRONT SIDE

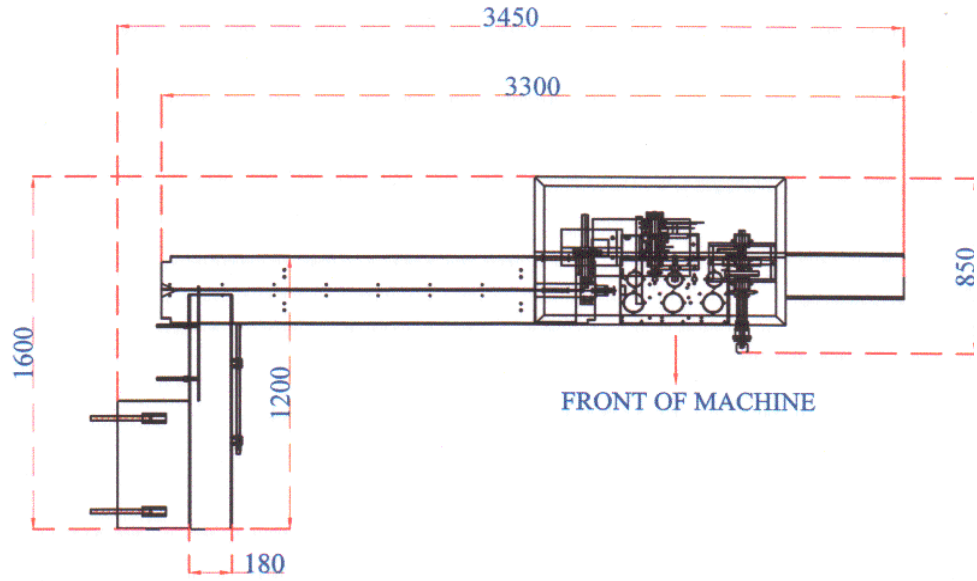

TYPE B FEEDING FROM BACK SIDE

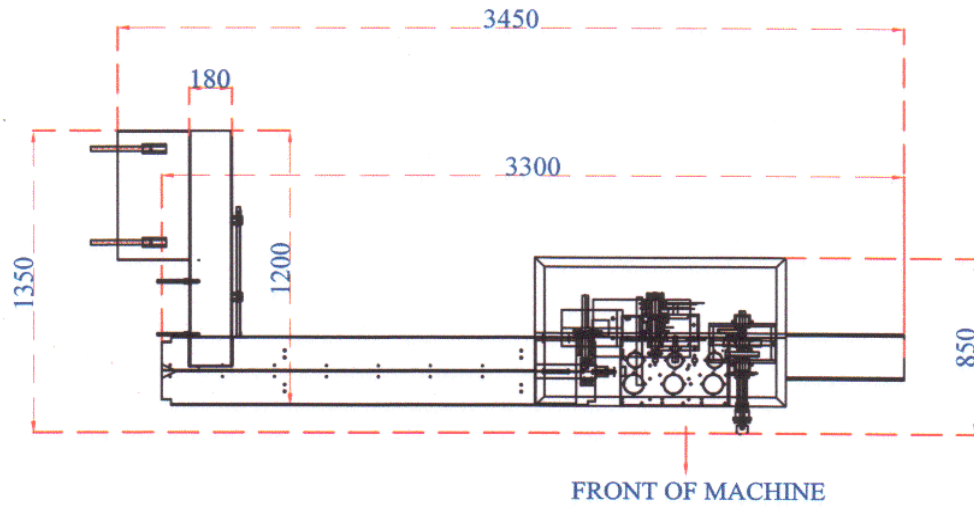

The all technical specification in this catalogue are with a view to presentation. ORME reserves to right to change specifications without prior notice -2/2-